

RADIOMETER

Type MS15
STANDARD SIGNAL GENERATOR

Electrical
measuring instruments for
industrial and scientific work

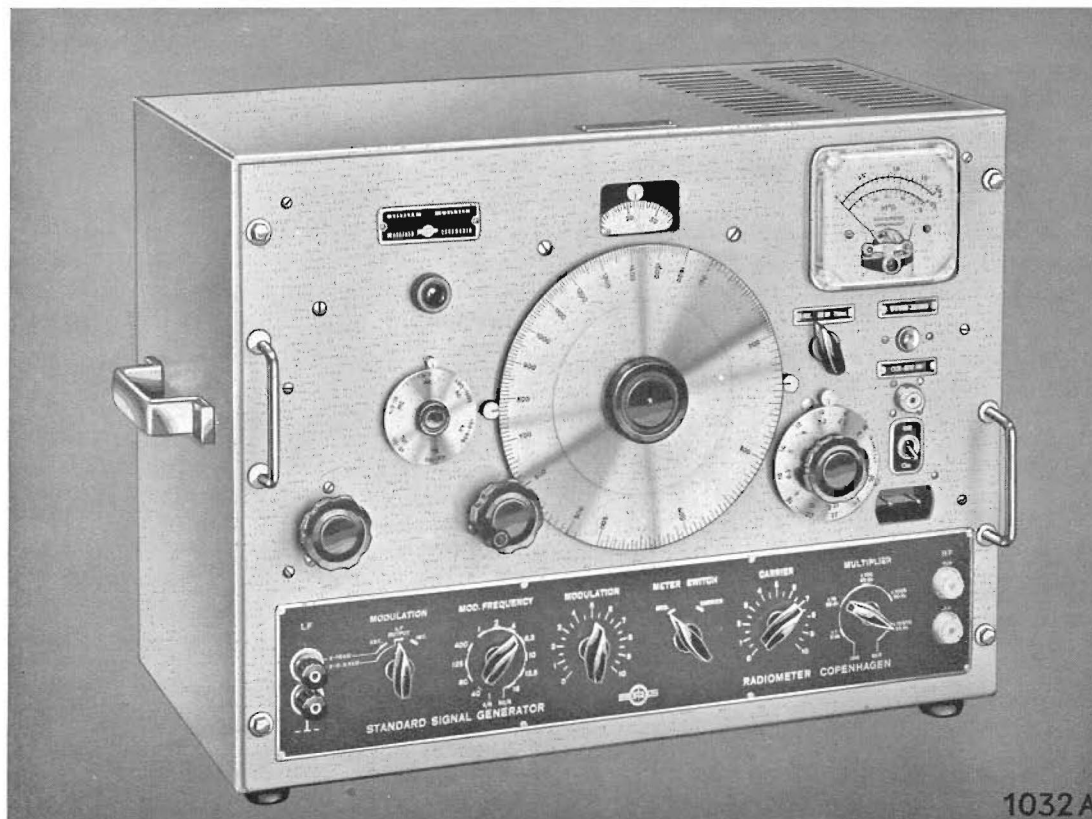



AM Standard-Signal Generator type MS15

50 kc - 50 Mc

(provisional data sheet)

Introduction :

The type MS15 is a precision instrument, built to meet severe requirements as to stability, versatility, low distortion, and freedom from stray radiation. In the design special attention has been given to the modulation circuit and phenomena as envelope distortion, sideband clipping and incidental FM are brought down to a minimum.

Special Features :

- * Automatic level control on carrier output
- * The carrier frequency is absolutely unaffected by the output control settings
- * Up to 90 % AM modulation with remarkably low distortion
- * 11 fixed modulation frequencies from a built-in oscillator
- * Very low incidental FM percentage on all ranges.

Description :

The type MS15 Standard-Signal Generator consists of a carrier frequency oscillator followed by a tuned buffer stage which operates as a frequency doubler. The buffer stage is followed by an aperiodic grid-modulated output stage, which feeds a resistive step-attenuator. The attenuator-input voltage is measured by a vacuum-tube voltmeter. Further the instrument contains a modulation-frequency oscillator and an electronically stabilized power supply.

The oscillator covers the range from 25 kc to 25 Mc in 6 ranges, providing for an output frequency range from 50 kc to 50 Mc. The oscillator and amplifier coils are mounted on a rotating turret.

An automatic level-control system which measures the carrier output and translates it into a regulating dc voltage, which is led back into

the buffer amplifier, provides for an output which remains virtually constant within the ranges up to at least 20 Mc. The desired attenuator input level can be set by means of a control knob on the front panel. Neither the automatic nor the manual level controls will affect the output frequency.

The AM modulation process takes place in an aperiodic output amplifier stage. In this way incidental FM and sideband cutting are easily kept very low.

The attenuator system consists of a 2 stage re-

sistive ladder attenuator. One stage covers 4 steps of 20 db and the other stage covers 10 steps of 2 db. The attenuator-input voltage is monitored by a balanced vacuum-tube voltmeter with a negligible zero drift.

The modulation-frequency oscillator is R-C tuned and provides for 11 fixed frequencies. The modulating voltage is measured by a germanium rectifier in connection with the carrier-frequency output meter which carries a modulation percentage scale.

SPECIFICATIONS

Carrier Frequency Range:

50 kc to 50 Mc in six direct-reading ranges:
 49 kc to 160 kc
 150 kc to 500 kc
 490 kc to 1600 kc
 1.5 Mc to 5 Mc
 4.9 Mc to 16 Mc and
 15 Mc to 50 Mc.

Frequency Calibration:

Accuracy $\pm 1\%$

Incremental Frequency Dial:

About 0.1 % per dial division on all ranges.

Frequency stability:

Drift during warm-up period is about 0.2 %. Half the maximum drift is reached in about 1 hour.

Frequency response:

The attenuator input level is kept within 1 db at 2 volts in the frequency range 50 kc to about 20 Mc.

Output:

Controlled by a two-stage attenuator, one with 10 steps of 2 db and the other with four steps of 20 db. Attenuator input monitored by vacuum tube voltmeter covering 0.2 to 2 volts with an additional db scale. Attenuator dials direct reading in microvolts as well as db over 1 microvolt. Voltage range 0.2 μ V to 2 volts on the whole frequency range.

Output impedance:

At one attenuator jack 10 Ω , at another jack 75 Ω except for the highest output position where it is 10 Ω higher. Output impedance at 2 volts panel jack is about 200 ohms.

Accuracy of Output Voltages:

At frequencies below 12 Mc: 0.5 db $\pm 0.1 \mu$ V.
 At frequencies above 12 Mc: 1 db $\pm 0.3 \mu$ V.
 At 2 volts panel jack: ± 0.2 db up to 12 Mc.

Internal modulating Oscillator:

11 fixed frequencies: 40—80—125—400 cps.
 1—2—4—6.3—10—12.5 and 16 kc.
 Accuracy $\pm 3\%$.
 Distortion: less than 0.5 % at 1 kc.

Amplitude Modulation:

Adjustable from zero to 90 %. Indication on panel meter accurate within $\pm 10\%$ of the indicated value.
 External modulation characteristic flat within ± 1 db from 30 cps to 16 kc.
 To provide 90 % modulation the external oscillator must supply about 11 volts into a 5 K Ω load at 1 kc.

Incidental Frequency Modulation:

At 90 % amplitude modulation the frequency modulation at all ranges is less than 10 parts in a million.

Carrier Distortion:

About 5 %

Envelope Distortion:

About 1 % at 30 % modulation, about 3 % at 80 % modulation, and about 5 % at 90 % modulation.

Carrier noise level:

Equivalent to about 0.1 % modulation.

Leakage:

Double shielding provides for negligible stray fields.

Power Supply:

110—127—150—200—220 or 240 volts 50—60 cps.
 a. c. Consumption: 75 watts.

Tubes:

1—EC81 or 6R4
 1—EBF80 or 6N8
 1—ECC81 or 12AT7
 1—PL83 or 15A6
 1—85A2 or 5651
 1—GZ32 or 5V4
 1—EB91 or 6AL5
 2—PL81 or 21A6
 4—EF80 or 6BX6

Overall Dimensions:

H: 380 mm. W: 560 mm. D: 270 mm.
 Front panel in accordance with 19" standard.

Mounting and Finish:

Grey enamelled steel cabinet.

Weight:

23.5 kilos.

Data subject to change without notice.

I N D E X

	page
DESCRIPTION:	
The h-f oscillator.....	1
The buffer stage.....	1
The modulated amplifier.....	3
The attenuator system.....	4
The vacuum-tube voltmeter.....	6
The modulation meter.....	6
The low frequency oscillator.....	7
The power supply.....	7
DIRECTIONS FOR USE.....	8
DUMMY ANTENNA.....	9
TUBE REPLACEMENT:	
Tube No. 1, 2, 3, and 4.....	10
Tube No. 5 and 6.....	11
Tube No. 7, 8, 9, 10, and 11.....	12
Tube No. 12 and 13.....	13
FUSES.....	13
ATTENUATORS.....	13

Type MS15 STANDARD SIGNAL GENERATOR

Description

The Standard Signal Generator consists of an unmodulated high-frequency oscillator, a tuned buffer stage operating as a doubler, a modulating stage, and two output attenuators. Besides it incorporates a low frequency oscillator with 11 fixed frequencies and a vacuum-tube voltmeter. The meter can be switched over to measure percentage modulation.

The h-f oscillator

consists of a triode (tube No. 1) operating in an eco coupling. The oscillator covers the range from 24.5 kc to 25 Mc in six direct reading ranges. A coil turret provides for switching from one range to another. The contacts between the tuning condenser and the coils at the turret are accomplished by means of vigorous bronze springs ensuring good contact and reliable operation of the oscillator. The 3 ranges 49-160 kc, 490-1600 kc, and 4.9-16 Mc use a common scale and so do the ranges 150-500 kc, 1.5-5 Mc, and 15-50 Mc. The accuracy is about 0.5%. The dial is individually engraved. During the warm-up period the frequency drifts about 0.2%. Half of the drift is reached during the first hour.

The friction drive of the tuning condenser provides for a smooth setting of the frequency. The incremental dial is coupled to the main shaft by means of spring loaded gears providing for a minimum of back-lash. The dial has 100 divisions, each one giving about 0.1% detuning.

The buffer stage

operates as a frequency doubler. It isolates the h-f oscillator completely from the modulating stage ensuring very little frequency modulation, amounting to only about 5 parts per million at 90% amplitude modulation. The tuning of the doubler circuit is accomplished simultaneously with the tuning of the oscillator by means of normal ganged condensers.

- 2 -

A small fraction of the voltage across the circuit is fed to the grid of the modulating tube (No. 4). The screen grid voltage of the buffer tube is regulated, thus providing for almost constant h-f input at the grid coupling condenser of the modulating tube. The automatic volume control system consists of a diode (tube No. 5), a d-c amplifier (tube No. 6) and a cathode follower (tube No. 3). The diode feeds a positive voltage of about 3 volts to the grid of the d-c amplifier which also gets about 4 volts negative voltage from the arm of the "CARRIER" potentiometer, resulting in about 1 volt negative grid-cathode voltage. The anode potential of the tube is fed to the grid of the tube No. 3 whose cathode is connected to the screen grid of the doubler tube. By setting the CARRIER control knob to the right position, the anode potential of the d-c amplifier, and consequently the screen grid voltage of the doubler, can be set to such a value that the output voltage of the signal generator is set to a predicted level. When the frequency is changed and the impedance of the doubler circuit changes, this will only give a minor variation in the output voltage because any attempt to change the h-f voltage at the input of the modulating tube and the diode results in a variation in the d-c potential at the grid of the d-c amplifier. This variation gives rise to an amplified variation at the screen grid of the doubler tube with opposite phase that almost outbalances the variation. With the output voltage at its normal level of 2 volts the output voltage only varies by about 0.5 db on all ranges except on the 15-50 Mc range where the output voltage is within 1 db up to 20 Mc. At 50 Mc the fall is about 5 db with the 2 volt jack disconnected. Otherwise it is about 6 db. With an output voltage smaller than 2 volts the regulation is correspondingly poorer.

As mentioned already, the output voltage from the signal generator is controlled by means of the knob CARRIER which controls the grid voltage of the d-c amplifier in the regulating system. By this means it is possible to set the output voltage at the 2 volt jack and thus at the input of the attenuator system to any value between 0.2 and 2 volts.

In order to reduce the mutual conductance of the doubler tube to the low value necessary for obtaining an output voltage of

0.2 volt at low frequencies where the impedance of the circuit is high, the third grid of the tube operates at a negative potential of about 30 volts. This voltage rises together with the screen grid voltage because the two grids are connected through a 1 megohm resistor providing for steeper regulation.

Owing to the limited Q of the doubler circuit a small amount of the oscillator frequency is present at the output. In the greater part of the frequency range there is only about 5%.

The modulated amplifier

consists of a 9 watt output penthode with a square law $i_a - V_g$ characteristic. The tube operates with grid modulation. Both the h-f and the l-f signal are fed to the grid. The high frequency components of the anode current are stopped by a choke and fed to the 20db step attenuator through a condenser. As the 50 kc high frequency voltage must be passed unattenuated to the attenuator, a 16 kc low frequency modulating voltage will also be present at the output with a voltage of about 0.8 volt at 30% modulation at the 2 volt jack. At 4 kc and 30% modulation there is only about 50 millivolts. In most cases this superimposed l-f voltage will be without importance, but if any disturbance occurs, the l-f voltage can be filtered out by means of a simple high pass filter.

The distortion of the modulation depends to some extent on the tube in question, but almost all tubes give a distortion which is less than 3% at 80% modulation. In general the distortion is about 0.4% at 30% modulation, about 0.7% at 50% modulation, about 1.5% at 80% modulation, and about 5% at 90% modulation. The hum modulation is only about 0.1%. Owing to the aperiodical modulation there is no side-band cutting.

The modulation may be either internal or external. At internal modulation the amplifier is modulated from a built-in l-f oscillator, at external modulation the source must be connected to the LF jacks. The input impedance is 10 kilohms, and about 4 volts are required for 30% modulation.

The modulation percentage is controlled by the knob MODULATION, both at internal and external modulation, and in both cases the

meter. The meter switch must be in position MOD. The accuracy is about 5% and the frequency range is 20 cps to 16 kc.

The modulation percentage is independent of the setting of the carrier output.

The excellent separation of the modulating stage from the oscillator by means of the doubler provides for negligible frequency modulation amounting only to about 5 parts per million at 90% amplitude modulation.

Due to the square law $i_a - V_g$ characteristic of the modulating tube the h-f output will have a second harmonic of about 5% at 2 volts at the attenuator. The distortion is proportional to the output voltage.

The attenuator system

consists of two attenuators in cascade. One attenuator has 10 steps of 2 db and the other has 4 steps of 20 db. The 2 db step attenuator is connected to the anode of the modulating tube through a condenser of about 15000 pF. The resonance circuit consisting of the anode choke of the modulating tube, the 15 nF coupling condenser, and the constant input resistance of 230 ohms of the 2 db step attenuator provides for a resonance frequency and Q of the circuit that compensates for the decreasing h-f voltage at the grid of the modulating tube when the frequency goes towards 50 kc. This decrease is due to the time constant of the RC link at the grid of the modulating tube being too small to pass the 50 kc voltage from the doubler unattenuated. The time constant cannot be made greater because the 16 kc modulating voltage will then be attenuated too much.

The dial of the 2 db step attenuator has a microvolt engraving and a db engraving with 0 db at 1 microvolt, and the dial of the 20 db step attenuator has also a db engraving. In addition figures are stated by which the microvolt readings at the 2 db step attenuator have to be multiplied in order to get the output voltage.

The output impedance at one h-f jack is 10 ohms for all positions of the 20 db step attenuator except the x10,000 position where it is 23 ohms. At the other h-f jack the output impedance is 65 ohms higher providing for correct termination of the 75 ohm antenna cable.

The input voltage of the attenuator system is also present at the jack "0.2-2V HF", when the 3 position output switch is set to position 2V HF, and the output impedance is about 200 ohms. If the outputmeter is used for setting the output voltage to a predicted level maintained independent of variations in the load, the output impedance is ostensibly zero.

An emf of 2 volts is available on the entire frequency range, and on the greater part of the range the max. emf is about 5 volts unmodulated.

With the output switch in position V_{\max} the attenuator is disconnected and the current normally drawn by it is now available at the output jack. The max. output current amounts to about 20 mA. The output voltage present is greatly dependent on the load. If the load is purely capacitive and the circuit (consisting of this capacity and the 1.5 millihenry choke) is in resonance with the output frequency range, the output voltage can be as high as 150 volts. In this case it is possible for the generator to deliver about 1 watt to a load between 5 and 10 kilohms, because the grid of the output tube (No. 4) can be excited as much as possible as the distortion of the anode current does not distort the output voltage appreciably, due to the filtering action of the resonant circuit.

The accuracy of the output voltage at 2 volts at the 2 volt jack is ± 0.2 db at frequencies below 12 Mc; at higher frequencies: ± 0.5 db.

The accuracy of the attenuator output is 0.5 db ± 0.1 μ V at frequencies below 12 Mc. Above 12 Mc it is 1 db ± 0.3 μ V.

Note: The resistors of the 20 db step attenuator are only rated for 0.1 watt and they will therefore only stand a current of about 0.1 amp. The attenuator should therefore never be exposed to voltages higher than 1 volt.

The vacuum-tube voltmeter

is of the balanced type ensuring a maximum of zero stability. It consists of the two diodes of the tube No. 6 and a double triode d-c amplifier operating as a cathode follower (tube No. 7). A built-in variable resistor with slotted shaft used for the calibration of the voltmeter is placed in series with the meter. The zero setting potentiometer is accessible from the front plate and can be set after a warm-up period of about 5 minutes.

The vacuum-tube voltmeter measures the input voltage at the attenuator system and the voltage at the "0.2-2V HF" jack if this jack is connected by setting the output switch to position 2V HF.

The dial of the meter is provided with a division for every 0.1 volt and it covers the range 0.1 to 2 volts. The 2-volt division is coloured because this division has to be used in order to make the engravings of the attenuator dials direct reading. A db scale is placed below the volt scale. Together with the db engravings of the attenuator dials it gives the output level in db over 1 μ V. Output voltages lying between the steps at the 2 db step attenuator can be read from the upper scale with almost maximum accuracy due to the approximately logarithmic scale. While adjusting the carrier, the modulation must be switched off if the modulating frequency exceeds 1 kc or 30% modulation, as otherwise the indication will not be correct.

The modulation meter

The meter is switched over to measure modulation percentage by setting the meter switch to its left-hand position. The meter operates with germanium rectifiers and measures the modulating voltage fed to the grid of the modulating tube, no matter whether internal or external modulation is used.

The meter is calibrated from 0 to 90% modulation with a division for every 5%. The accuracy of the indication is about $\pm 5\%$.

The low frequency oscillator

has 11 fixed frequencies: 40-80-125-400 cps - 1-2-4-6.3-10-12.5, and 16 kc. The accuracy is $\pm 3\%$ and the distortion is less than 0.5% at all frequencies at 50% modulation. At 90% modulation the distortion is slightly greater at the higher frequencies, due to the heavier load represented by the decreasing upper part of the modulation potentiometer in series with the lead-through capacitors on the lead to the grid of the modulating tube. The hum at the l-f output is less than 0.05%.

By means of the potentiometer MODULATION a part of the l-f output voltages is used for the modulation and measured by means of the modulation meter, which is directly calibrated in modulation percentage.

The output of the l-f oscillator is fed to the potentiometer MODULATION when the switch MODULATION is set to position INT. With the switch at position EXT. an l-f voltage fed to the l-f jacks can modulate the generator. About 4 volts across 10 k Ω are used for 30% modulation.

With the modulation switch at position L.F. OUTPUT the voltage at the slider contact of the potentiometer generated by the built-in oscillator is also present across the l-f terminals. The max. output voltage is about 15 volts, and the output impedance varies between 0 and 2.5 k Ω . The output current must not exceed a few milliamps, as otherwise the distortion will rise.

The power supply

is electronically regulated, thus providing for the low output impedance and stability against line voltage variations. Both the vacuum-tube rectifier and the selen rectifier are protected against short circuit of the electrolytic buffer condenser by means of fuses mounted next to the line transformer.

The regulated voltage can be set to the correct value - 160 volts - by means of an internal potentiometer with slotted shaft.

The instrument operates from a 50-60 cycle power line. The voltage selector can be set to the following voltages: 110, 127, 150, 200, 220, or 240 volts, a-c. The consumption is about 75 watts. The 2 amp fuse on the voltage selector must be replaced by a fuse of higher amperage when switching over to a line voltage lower than 200 volts.

Directions for use

Before connecting the Signal Generator to the a-c power line make sure that the voltage selector at the line transformer is set at the line voltage available. When the instrument leaves the factory the voltage selector is set at 220 volts and provided with a 2-amp fuse which will protect the transformer in case the generator is connected to a d-c power line by mistake.

Start the Signal Generator with the power switch, and allow it to warm up for some minutes. Check the mechanical zero of the meter with the meter switch in its center position. Switch over to position CARRIER and set the electrical zero by means of the potentiometer with slotted shaft - VTVM ZERO - with the frequency range switch so set that the oscillator does not operate. Select the frequency range in question, set the output switch to position ATT., and set the meter needle to the red 2-volt line of the scale by means of the knob CARRIER without modulation. The attenuator dials are now direct reading in microvolts or db over 1 microvolt. The microvolts are had by multiplying the readings of the two dials and the db over 1 μ V by adding the db readings.

The output impedance at the two attenuator jacks is 10 Ω and 75 Ω , respectively, for all settings of the attenuators except for the x10,000 position of the 20 db step attenuator where it is 10 Ω higher. Voltages between 0.2 μ V and 0.2 volt are available at the two jacks on the entire frequency range. Set the output switch to position 2V HF and unscrew the shielding nut covering the jack "0.2 - 2V HF", if an output voltage in this range is required. The output impedance is about 200 ohms, and the 2 volt output is only had if the load impedance

is great compared with 200Ω , but a peak voltage of about 1 volt is available across a load of 75Ω on the greater part of the frequency range.

The output impedance can be made zero by setting the output voltage to a predicted level by means of the CARRIER knob when variations in the load or the frequency alter the output voltage.

Set the output switch to position V_{\max} if a maximum voltage or a maximum current is desired. The output impedance is about 1.5 millihenry and the output voltage depends on the load and is about 150 volts maximum. The maximum output current is about 20 milliamps.

Set the modulation switch to position LF OUTF. if a voltage is required at one of the 11 fixed frequencies. The voltage modulating the Signal Generator is then present across the LF terminals. The maximum output voltage is about 15 volts. The output impedance depends on the position of the knob MODULATION. It varies between 0 and $2.5\text{ k}\Omega$.

Dummy antenna

A type KA4 Dummy Antenna can be supplied with the Signal Generator.

The antenna is constructed according to American standards and consists of 200 pF in series with 20 microhenrys. 400 pF is placed over the coil in series with 400 ohms. The antenna has practically the same impedance as a 200 pF capacitor at frequencies below 1.5 Mc, and at frequencies higher than 6 Mc it is almost 400 ohm resistive.

The components of the antenna are mounted in a small aluminium probe fitted at the end of an h-f cable with a PL259 connector. Two banana plugs are fitted on the probe 19 mm apart. The CHASSIS plug which is knurled at the neck can be unscrewed. A connector can be supplied, fitting both the dummy antenna and a radio receiver with flat antenna plug and chassis plug perpendicular to each other.

TUBE REPLACEMENT

Tube No. 1 is a type EC81 or 6R4 operating as an h-f oscillator in the range 25 kc to 25 Mc. After replacement it may be necessary to adjust the trimmers by means of a socket wrench about 10 cm long through the lowest hole but one at the back of the internal shield. The shield can be removed after loosening the screws that squeeze it between the two front shields.

The negative voltage at the grid lies between about 25 and about 35 volts, except on the highest frequency range where the voltage varies between minus 15 and minus 30 volts.

Tube No. 2 is a type EF80 or 6BX6 operating as a frequency doubler. The grid is loosely coupled to the oscillator circuit and gets a voltage of about minus 10 volts by grid rectification. The anode voltage is constant and about 290 volts, but the voltages at the screen grid and the suppressor grid are greatly dependent on the setting of the CARRIER knob and the frequency. At 2 volts h-f output the screen grid operates at about 40 volts at lower frequencies and at about 150 volts at 50 Mc. The suppressor grid lies at a negative voltage of about 35 volts except on the highest frequency range where the voltage is about 20 volts. The tube can be replaced right away. Only a few tubes supply a too low voltage to the modulating tube in the 15-50 Mc range. Replacement may perhaps necessitate an adjustment of the trimmers. The trimmers are set so that the screen grid voltage is at its minimum.

Tube No. 3 is also an EF80 or 6BX6 operating as a cathode follower. It can be replaced right away.

Tube No. 4 is a type PL81 or 21A6 operating as a modulator. As the distortion of the modulation is only dependent on the characteristic of this tube the distortion should always be checked after the replacement. A convenient way to do so is by measuring the side bands separately by means of a type FRA1 Radiometer Wave Analyzer, which is a very selective superheterodyne receiver with double conversion. As the first intermediate frequency is 50 kc and the oscillator operates in the range 50 kc to 34 kc

the two ranges from 0-6 kc and from 100 kc to 84 kc are covered. By setting the dial of the FRA1 to e.g. 3 kc the instrument also becomes sensitive to 97 kc, and if the Standard Signal Generator is operated at this frequency and e.g. modulated with 400 cps, the carrier is found at the dial at 3 kc and the side bands of first order at 3.4 kc and 2.6 kc. The side bands which are due to the distortion of the modulation lie at 3.8 kc - 4.2 kc - 4.6 kc and so on, and symmetrically with respect to 3 kc. The side bands due to hum modulation are located at 3050-3100 and 3150 cps, and at 2950-2900 and 2850 cps, and are measured with 2 cps band-width at the Wave Analyzer. (See the appended data sheet for type FRA1 Wave Analyzer).

The cathode of tube No. 4 operates at about 17 volts and the anode and screen grid at 160 volts. If it is impossible to find a tube with less than 3% distortion at 80% modulation it may be an improvement to replace the unsurpassed 22Ω cathode resistor. In general about 50% of all tubes are usable.

Tube No. 5 is a type EB91 or 6AL5 diode which feeds a positive voltage proportional to the h-f voltage at the grid of tube No. 4 to the grid of tube No. 6. A small increase (or decrease) in this rectified voltage is followed by an amplified decrease (or increase) in the screen grid voltage of the doubler tube feeding the diode so that the increase (or decrease) is almost eliminated. The tube can be replaced right away.

Tube No. 6 is a type EBF80 or 6N8 operating as a d-c amplifier for the positive voltage fed to it from the automatic volume control diode. In order to obtain a normal point of operation a negative voltage is also fed to the grid from the CARRIER potentiometer providing for a resulting negative voltage at the grid of about 1 volt. The screen grid voltage is about 10 volts. The anode voltage is greatly dependent on the h-f output voltage and the frequency, and it is about 50 volts at 1 Mc with 2 volts h-f output.

The two diodes of the tube are used for the voltmeter that measures the h-f output voltage. The one diode rectifies the h-f voltage, the other is used for balancing out the small alter-

ations of the initial current due to variations in the heater current caused by line voltage variations. The two d-c voltages from the diodes are fed to tube No. 7.

Tube No. 7 is a type ECC81 or 12AT7 double triode operating as a cathode follower to which the meter is connected. After replacement one of the cathode resistors will perhaps have to be changed so as to make the zero of the meter remain within the limits of the ZERO potentiometer.

The grids operate at minus 2.8 volts and minus 0.7 volt and the cathodes at about +0.5 volt and about +2.5 volts, respectively. The voltage at the common cathode resistor is about minus 12 volts. All voltages are referred to chassis.

Tube No. 8 is a type EF80 or 6BX6 penthode operating as the first amplifying stage in a two-stage R-C Generator.

The voltage at the anode is about 100 volts and at the cathode about 0.8 volts, while the 1 kc voltages are about 4 volts and 3 volts, respectively. The tube can be replaced right away.

Tube No. 9 is a type PL83 or 15A6 output penthode operating as the second stage in the RC Generator.

The voltage at the cathode is about 3 volts and at the anode about 200 volts. The 1 kc voltages are about 1.8 volts and 20 volts, respectively. The tube can be replaced right away.

Tube No. 10 is a type PL81 or 21A6 output penthode operating as the series tube in an electronically regulated power supply.

The anode voltage is about 290 volts at nominal line voltage with about 250 millivolt hum. The cathode is set to 160 volts by means of the grid of tube No. 11. The tube can be replaced right away.

Tube No. 11 is a type EF80 or 6BX6 penthode operating as a d-c amplifier in the electronically regulated power supply.

The grid voltage is about minus 5.5 volts and the anode voltage

is about 145 volts. The voltage at the screen grid is about 200 volts. The tube can be replaced right away.

Tube No. 12 is a type 85A2 or 5651 glow-discharge tube the cathode of which has a potential of minus 85 volts referred to chassis. The current through the tube is about 4 mA and varies about 1 mA for a line voltage variation of 10%. The tube can be replaced right away.

Tube No. 13 is a type GZ32 or 5V4 rectifier which can be replaced right away.

Fuses: At the line voltage selector is mounted a 2 amp fuse which protects the transformer against damage if the signal generator is connected to a d-c line by mistake. When switching over to a lower line voltage the fuse must be replaced by a fuse of correspondingly higher amperage.

Both the rectifying tube and the selenium rectifier are protected by means of fuses against damage if the electrolytic buffer condensers should short-circuit. The former with a 0.2 amp fuse, the latter with a 0.1 amp fuse.

Attenuators

The 2 db step attenuator can be removed for repair after the coupling between the two front shields has been loosened by unscrewing the two screws holding the plate carrying the attenuator. The coupling becomes visible after the cover over the h-f filters has been removed.

The 20 db step attenuator can be dismantled as follows: Remove the internal shield and unsolder the connection to the 2 db step attenuator. Unscrew the nut that clamps the shield of the cable between the two attenuators to the feed-through bushing and pull out the cable. Also remove the etched front plate and unscrew the screws holding the attenuator and the brass piece carrying the two h-f jacks. The attenuator can now be removed and taken apart without difficulty.



816 E

Wave Analyzer type FRA 1

Introduction:

The Wave Analyzer is in principle a selective audio-frequency voltmeter. The type FRA1 is especially designed for measuring the separate components of any complex AC-voltage, in terms of frequency and amplitude from a few microvolts to 400 volts, within the frequency range 20—16000 cycles.

Some examples of its numerous uses are the measurement of the components of harmonic distortion, intermodulation distortion, frequency and amplitude modulation spectra, hum and noise.

Special Features:

Variable bandwidth.

Direct reading incremental frequency dial.

Simple and easy balancing and adjusting procedure. Output jack from which a signal proportional to the meter reading can be taken, e.g. for recording purposes. Provision for coupling the frequency dial to the recorder.

Description:

The principle of the Wave Analyzer is much like that of a double-conversion superheterodyne receiver, and is illustrated in the schematic diagram fig. 2: The incoming signal is mixed in a balanced 1. converter with a carrier signal whose frequency is controlled by the main dial. When the carrier is so adjusted that the sum of its frequency and that of one of the components of the signal equals 50 kc the resultant signal is passed through a 50 kc band-pass filter. After the 50 kc filter the signal is mixed in a 2. converter with a 51.5 kc carrier

and the resultant 1.5 kc difference-frequency signal is passed through a selective 1.5 kc band-pass filter. After a final amplification the signal amplitude is measured on a meter.

The input circuit consists of a 20 db/step voltage divider (Input Multiplier) for changing the voltage range of the instrument, and a continuously variable potentiometer, which can be switched in or out of the circuit at will.

The 1. converter is balanced to minimize disturbances from the 1. oscillator when its frequency approaches 50 kc. The main dial is calibrated to indicate the input frequency to which the instrument is sensitive. The 2. oscillator can be varied by ± 25 cycles by means of an incremental

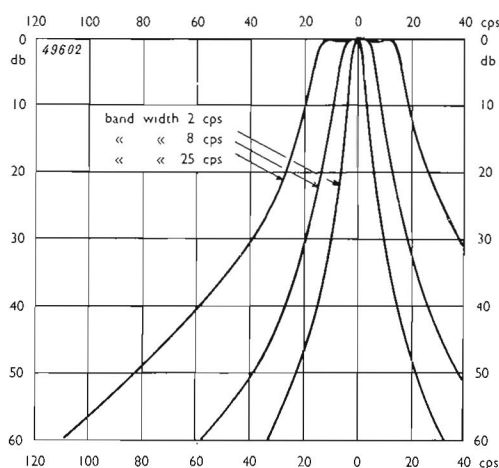

Fig. 1: Typical response curves.

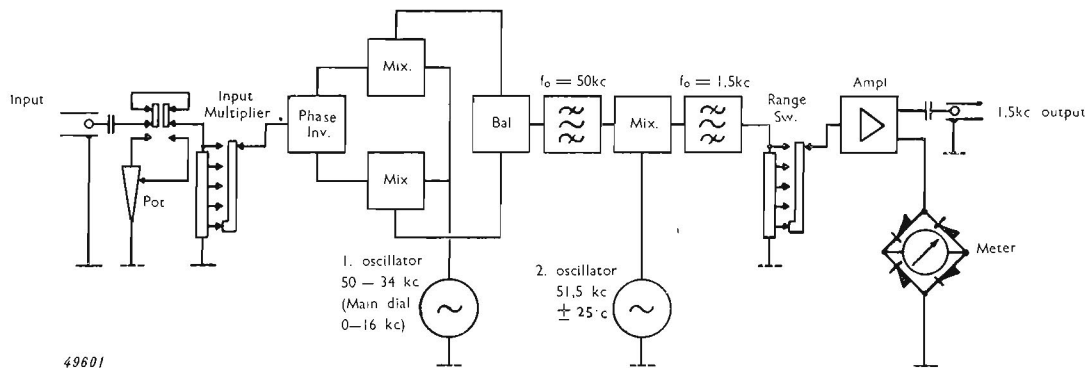

Fig. 2: Functional schematic diagram of the Wave Analyzer.

frequency dial for fine-tuning of the instrument. The 1.5 kc band-pass filter determines the bandwidth of the instrument. The filter has approximately flat-top response and is adjustable to 2, 8, and 25 cycles bandwidth, cf. fig. 1. The remaining parts of the instrument are essentially a vacuum-tube voltmeter consisting of a voltage divider (Range Switch), an amplifier, and a meter. After an initial phase balancing the instrument is calibrated by tuning to an internally provided power-frequency signal and adjusting the amplification against a built-in voltage divider. The calibration thus becomes independent of line voltage variations. The power supply is electronically stabilized to minimize the influence of line voltage variations, and the heater current for the first tubes is rectified and filtered to minimise hum.

Special Design type FRA1T: This instrument contains an auxiliary beat-frequency oscillator which from an extra output terminal supplies a frequency $F-A$ where F is the main dial reading and A is a frequency which can be set on an auxiliary dial, i.e. the oscillator frequency keeps a constant difference, A , from the frequency to which the analyzer is tuned. A is variable from 0 to 500 cycles. With A set to zero the type FRA1T is especially useful when measuring on selective networks. Further it can be used when measuring on microphones or loudspeakers at relatively high noise levels. When the auxiliary dial is set to a value differing from zero the instrument may be used in connection with a few simple supplementary instruments to measure intermodulation in a-f transmission systems.

SPECIFICATIONS:

Type FRA1:

Frequency range: 20 to 16000 cycles. Main dial (F) 0-16000 cycles, linear 0 to 100 cycles, logarithmic 100 to 2000 cycles, and linear 2000 to 16000 cycles. Incremental frequency dial, ± 25 cycles.

Accuracy of frequency calibration: 1% + 1 cycle.

Selectivity: The bandwidth of the Wave Analyzer is variable in 3 steps:

"2 cycles":	1db down at \pm	1 cycle
	60 "	" " \pm 35 "
"8 cycles":	1db " " \pm	4 "
	60 " " " \pm	55 "
"25 cycles":	1db " " \pm	12,5 "
	60 " " " \pm	110 "

Voltage range: 100 microvolts to 1000 volts full scale in 15 ranges. Meter scale: 0 to 10, 0 to 32 and -10 to +10 db. Input multiplier with 4 steps of 20 db. Range switch: 6 steps of 10 db. Lowest voltage detectable: 3 μ V. Max. input voltage 400 volts.

Voltage accuracy: Voltages are measured with an accuracy of 0.5 db from 30 cycles to 16 kc. Corrections for frequencies below 30 cycles are given in a chart supplied with the instrument. Harmonics and spurious voltages generated within the Analyzer are suppressed by at least 75db for all dial settings above 100 cycles. Below 100 cycles the suppression gradually decreases to about 60 db. Equivalent hum voltage: below 15 microvolts.

Input impedance: The input circuit is unbalanced (cf. the schematic diagram). When using the Input Mul-

tiplier directly the input impedance is 2 megohms shunted by 12 to 25 picofarads. When using Potentiometer Input the impedance is 0.2 megohms shunted by 15 - 40 picofarads.

Power supply: 110, 127, 150, 200, 220, and 240 volts 50 to 60 cycles. Consumption about 50 watts.

Tubes: 3 ECH42, 6 EF40, UL41, EZ40, 85A1.

Overall dimensions: H: 420 mm, W: 570 mm, D: 310 mm.

Mounting and finish: Grey enamelled metal cabinet. Panel drilled to fit 19" relay rack.

Weight: 32 kilos.

Special Design type FRA1T

Auxiliary oscillator dial (A): 0-500 cycles. Accuracy 2% + 2 cycles.

F-A output: 0 to 10 volts, continuously variable. Output impedance 500 ohms, one terminal grounded. Minimum load impedance 20 kilohms. At 10 volts and 50 kilohm load the distortion is less than 1%. The frequency response is within ± 0.5 db from 30 cycles to 10 kc and within ± 1.5 db up to 16 kc.

Sray coupling to Analyzer: With A set to zero the internal leakage from the aux. oscillator to the analyzer amounts to about 30 μ V, referred to the signal grid of the phase inverter.

Other specifications as for type FRA1.

Data subject to change without notice.



